

NOTES:

1. REFER TO ASME Y14.5M-1994 FOR GEOMETRIC DIMENSIONING AND TOLERANCING STANDARDS
2. REFER TO ASSEMBLY MODEL FOR ANY NON-DIMENSIONED GEOMETRY (SURFACES ACCURATE TO +/- 0.100)
3. FINISH: NONE
4. TRACEABILITY: PHARAD S/N
5. PART MARKING: PHARAD LABEL 101108-014
6. ASSEMBLE PER PHARAD WORK INSTRUCTION 900008
7. TEST ASSEMBLY PER PHARAD WORK INSTRUCTION 900009

REVISIONS				
ZONE	REV.	DESCRIPTION	DATE	APPROVED
N/A	A	ENGINEERING PROTOTYPE	12/14/2010	JDM
N/A	A-01	REVISED POUCH LABEL TO INCLUDE S/N	2/21/2011	JDM

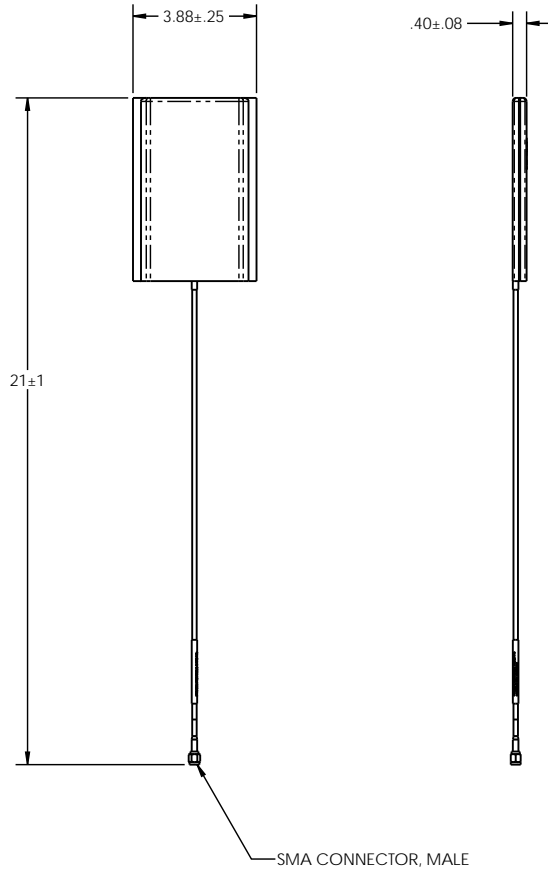

SMA CONNECTOR, MALE

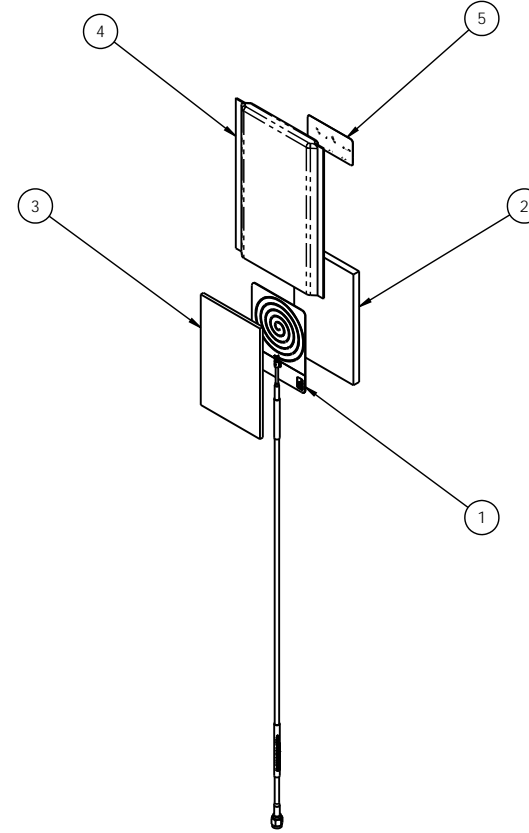

ITEM NO.	PART NUMBER	DESCRIPTION	QTY.
1	100540	RADIATOR SUB-ASSEMBLY, WEARABLE ANTENNA, 1228/1575 MHz	1
2	100491-003	FOAM, WEARABLE ANTENNA, .25 THICK, 4.25 X 2.63	1
3	100492-003	FOAM, WEARABLE ANTENNA, .125 THICK, 4.25 X 2.63	1
4	100493-003	POUCH, WEARABLE ANTENNA, 5.75 X 3.88	1
5	101110	LABEL, WEARABLE ANTENNA, POUCH, BARCODE	1
6	100873	MCNETT SEAM GRIP	1

PROPRIETARY AND CONFIDENTIAL
 THE INFORMATION CONTAINED IN THIS DRAWING IS THE SOLE PROPERTY OF PHARAD, LLC. ANY REPRODUCTION IN PART OR AS A WHOLE WITHOUT THE WRITTEN PERMISSION OF PHARAD, LLC IS PROHIBITED.

UNLESS OTHERWISE SPECIFIED: DIMENSIONS ARE IN INCHES		NAME	DATE	PHARAD, LLC 197 CROMWELL PARK DRIVE, SUITE V GLEN BURNIE, MD 21061 TITLE: ASSEMBLY, WEARABLE ANTENNA, 1228/1575 MHz SIZE DWG. NO. REV C 100568 A-01 SCALE: 1:3 SHEET 1 OF 1
TOLERANCES: TWO PLACE DECIMAL ±.010 THREE PLACE DECIMAL ±.005 ANGULAR ±1°		DRAWN	JDM	
MATERIAL		CHECKED		
SEE NOTES		ENG APPR.		
FINISH		MFG APPR.		
DO NOT SCALE DRAWING		COMMENTS:		